



**NOTICE OF MEETING
OF THE
HISTORIC PRESERVATION COMMISSION
OF
BUDA, TEXAS**

An agenda information packet is available for public inspection in the Buda Public Library.

This notice is posted pursuant to the Texas Open Meeting Act. Notice is hereby given that a **Special Meeting of the Historic Preservation Commission** of the City of Buda, Texas will be held on **Thursday, October 1, 2015 at 7:00 p.m.** in the Council Chambers at Buda City Hall at 121 Main Street, Buda, Texas 78610, at which time the following subjects will be discussed:

A. CALL TO ORDER

B. INVOCATION

C. PLEDGE OF ALLEGIANCE TO THE FLAGS OF THE UNITED STATES AND TEXAS

PLEDGE OF ALLEGIANCE TO THE TEXAS FLAG: *Honor the Texas flag; I pledge allegiance to thee, Texas, one state under God, one and indivisible.*

D. ROLL CALL

E. PUBLIC COMMENTS At this time, comments will be taken from the audience on non-agenda related topics, for a length of time not to exceed three minutes per person. To address the Historic Preservation Commission, please submit a Citizen's Comment Form to the Staff Liaison **prior** to the start of the meeting. *No action may be taken by the Historic Preservation Commission during Public Comments.*

F. CONSENT AGENDA

1. Approval of the regular Historic Preservation Commission meeting minutes dated May 7, 2015.

G. PUBLIC HEARINGS

1. Hold a public hearing in regard to a request for a Certificate of Design Compliance for a freestanding sign located at 107 S. Austin Street (Perky Penny Papers).
2. Hold a public hearing in regard to a request for a Certificate of Design Compliance for a freestanding sign located at 304 S. Main Street, Suite 101 (Stella's Consignment).

H. REGULAR AGENDA ITEMS

1. Deliberation and possible action in regard to a request for a Certificate of Design Compliance for a freestanding sign located at 107 S. Austin Street (Perky Penny Papers).
2. Deliberation and possible action in regard to a request for a Certificate of Design Compliance for a freestanding sign located at 304 S. Main Street, Suite 101 (Stella's Consignment).

I. STAFF REPORTS

The Historic Preservation Commission may discuss any of the items under Staff Reports, but no formal action will be taken.

- Update on Historic Preservation activities within the city limits and Extraterritorial Jurisdiction (ETJ)
- Update on Certificate of Design Compliance cases, including cases of insignificant alterations
- Staffing update

J. COMMISSION REQUESTS FOR FUTURE AGENDA ITEMS

No deliberation or discussion may take place by the Commission during this agenda item.

K. ADJOURNMENT

I, the undersigned authority, do hereby certify that the above Notice of Meeting of the Governing Body of the City of Buda, was posted on the bulletin board in front of Buda City Hall, which is readily accessible to the public at all times, by 7:00 p.m. on Monday, September 28, 2015.



Chance Sparks, AICP, CNU-A
Director of Planning

City Hall is wheelchair accessible and accessible parking spaces are available. Requests for accommodations must be made 48 hours prior to the meeting. Please contact the City Secretary at (512) 312-0084, or FAX (512) 312-1889 for information or assistance.

AGENDA NOTICES:

Council Chambers are set up to publicly broadcast meetings. You may be audio and video recorded while in this facility.

Attendance by Other Elected or Appointed Officials:

It is anticipated that members of other governmental bodies, and/or city boards, commissions and/or committees may attend the meeting in numbers that may constitute a quorum of the body, board, commission and/or committee. Notice is hereby given that the meeting, to the extent required by law, is also noticed as a possible meeting of the other body, board, commission and/or committee, whose members may be in attendance, if such numbers constitute a quorum. The members of the boards, commissions and/or committees may be permitted to participate in discussions on the same items listed on the agenda, which occur at the meeting, but no action will be taken by such in attendance unless such item and action is specifically provided for on an agenda for that body, board, commission or committee subject to the Texas Open Meetings Act.

CITY OF BUDA
HISTORIC PRESERVATION COMMISSION
REGULAR MEETING MINUTES
JULY 2, 2015 7:00 P.M.

A. CALL TO ORDER

Vice Chair Brinkley called the regular meeting of the Historic Preservation Commission to order at 7:03 p.m.

B. INVOCATION

C. PLEDGE OF ALLEGIANCE TO THE FLAGS OF THE UNITED STATES AND TEXAS

PLEDGE OF ALLEGIANCE TO THE TEXAS FLAG: *Honor the Texas flag; I pledge allegiance to thee, Texas, one state under God, one and indivisible.*

D. ROLL CALL

Vice-Chairman Nancy Brinkley	Absent - <i>Excused</i>
Commissioner Leonard Diggs	Present
Commissioner Frank Morgan	Absent
Commissioner Holly Glickler	Present
Commissioner Thomas Hughes	Present
Commissioner Belinda Ellis	Absent
Chairman Nate Wensowitch	Present

E. PUBLIC COMMENTS

At this time, comments will be taken from the audience on non-agenda related topics, for a length of time not to exceed three minutes per person. To address the Historic Preservation Commission, please submit a Citizen's Comment Form to the Staff Liaison **prior** to the start of the meeting. *No action may be taken by the Historic Preservation Commission during Public Comments*

No public comments were made.

F. PUBLIC HEARINGS

1. Hold a public hearing in regard to a request for a Certificate of Design Compliance for a wall sign located at 305 Railroad Street (Prosper Properties).

Chair Brinkley opened the public hearing at 7:06 p.m.

No comments were made.

Chair Brinkley closed the public hearing at 7:06 p.m.

2. Hold a public hearing in regard to a request for a Certificate of Design Compliance to construct a new dwelling at 216 South Cedar Street.

Chair Brinkley opened the public hearing at 7:07 p.m.

No comments were made.

Chair Brinkley closed the public hearing at 7:07 p.m.

G. CONSENT AGENDA

1. Approval of the regular Historic Preservation Commission meeting minutes dated May 7, 2015.

Commissioner Wensowitch made a motion to approve this item.

Commissioner Hughes made a second to the motion.

The motion was approved unanimously.

H. REGULAR AGENDA ITEMS

1. Deliberation and possible action in regard to a request for a Certificate of Design Compliance for a wall sign located at 305 Railroad Street (Prosper Properties).

Staff presented the item to the Commission. Commissioner Hughes made a motion, seconded by Commissioner Wensowitch, to approve the request. The motion was approved unanimously.

2. Deliberation and possible action in regard to a request for a Certificate of Design Compliance to construct a new dwelling at 216 South Cedar Street.

Staff presented the item to the Commission. Commissioner Wensowitch made a motion, seconded by Commissioner Hughes, to approve the request. The motion was approved unanimously.

3. Deliberation and possible action in regard to the Historic Preservation Awards selections.

Staff presented the item to the Commission. Commissioner Glickler made a motion, seconded by Commissioner Diggs, to approve the request. The motion was approved unanimously.

4. Presentation and discussion regarding the 2014 General Obligation Bond Program progress.

Staff presented the item to the Commission.

5. Presentation and discussion regarding the Fiscal Year 2015-2016 Capital Improvements Plan.

Staff presented the item to the Commission.

I. STAFF REPORTS

The Historic Preservation Commission may discuss any of the items under Staff Reports, but no formal action will be taken.

- Update on Historic Preservation activities within the city limits and Extraterritorial Jurisdiction (ETJ)
- Update on Certificate of Design Compliance cases, including cases of insignificant alterations

J. COMMISSION REQUESTS FOR FUTURE AGENDA ITEMS

No deliberation or discussion may take place by the Commission during this agenda item.

No items were requested.

K. ADJOURNMENT

Commissioner Hughes made a motion to adjourn the meeting.

Commissioner Glickler made a second to the motion.

After a unanimous vote in favor of the motion, and having no further business to consider, Chairman Wensowitch adjourned the meeting at 8:05 p.m.

ATTEST:

Chair
Historic Preservation Commission

ATTEST:

Recording Secretary



Historic Preservation Commission Agenda Item Report October 1, 2015

Contact – Meredith Johnson / Planner
512-312-5745 / MJohnson@ci.buda.tx.us

SUBJECT: DELIBERATION AND POSSIBLE ACTION IN REGARD TO A REQUEST FOR A CERTIFICATE OF DESIGN COMPLIANCE FOR THE INSTALLATION OF A FREESTANDING SIGN LOCATED AT 107 S AUSTIN ST.

1. BACKGROUND/HISTORY

This is the regular agenda item (action item) for a Certificate of Design Compliance (CDC) application for the installation of a freestanding sign located at 107 S Austin St for Perky Penny Papers, a craft store that recently moved to this address.

The City of Buda Unified Development Code requires that work in the Historic District which requires a new sign permit shall have CDC approval prior to issuance of the permit.

2. CURRENT STATUS

The applicant is proposing a 2.5' by 9' sign to be installed in front of the building, facing Austin Street. The sign will be on posts that are approximately 8' tall. The applicant is choosing a freestanding design due to the windows and corrugated metal already on the building. It will replace the older hanging sign structure left from when B&B Quilting was located in the building. The building is not considered a significant contributing structure to the district.

Sign Design

The proposed sign is white with black writing and an image of a dog.

3. FINANCIAL IMPACT

N/A

4. ACTION OPTIONS/RECOMMENDATION

Staff recommends approval of this request because the sign meets the UDC standards and fits within the context of the Historic District and within the context of the alterations made to the structure.

5. ENCLOSURES

Sign Proposal



Perky Penny Papers[®]
Craft Gym & Store

.... a place to exercise your creativity

Affordable Paper Crafting Supplies, Workspace, Classes, and more.....

Drawing is not to exact scale

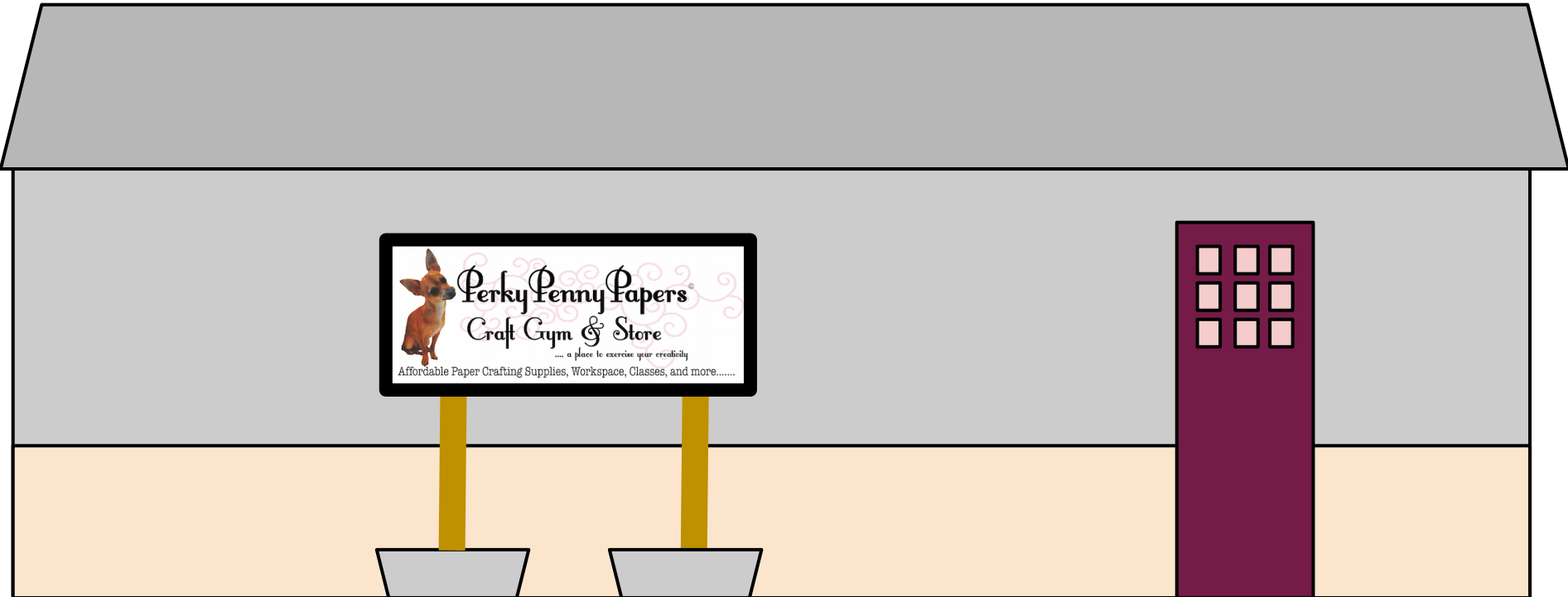



Historic Preservation Commission Agenda Item Report October 1, 2015

Contact – Meredith Johnson / Planner
512-312-5745 / MJohnson@ci.buda.tx.us

SUBJECT: DELIBERATION AND POSSIBLE ACTION IN REGARD TO A REQUEST FOR A CERTIFICATE OF DESIGN COMPLIANCE FOR THE INSTALLATION OF A FREESTANDING SIGN LOCATED AT 3045 S. MAIN ST, SUITE 101.

1. BACKGROUND/HISTORY

This is the regular agenda item (action item) for a Certificate of Design Compliance (CDC) application for the installation of a freestanding sign located at 304 S. Main St, Suite 101, for Stella's Consignment, a high-end consignment store that recently moved into Buda Mill and Grain.

The City of Buda Unified Development Code requires that work in the Historic District or Central Business District which requires a new sign permit shall have CDC approval prior to issuance of the permit.

2. CURRENT STATUS

The applicant is proposing a 3' by 2' sign to be installed in front of the building, facing Main Street. The sign will hang within a frame that measures approximately 3.5' by 4.5'. The sign itself will be artistically cut in the shape shown on page 2 of the attached design. It will hang within a two post metal frame from chains. The metal frame will match the patina of other metal elements within Buda Mill & Grain.

Sign Design

The proposed sign is white with black writing, blue trim, and images of multi-colored flowers on a beige/cream background.

3. FINANCIAL IMPACT

N/A

4. ACTION OPTIONS/RECOMMENDATION

Staff recommends approval of this request because the sign meets the UDC standards and fits within the context of the Historic District and within the context of the alterations made to the structure.

5. ENCLOSURES

Sign Proposal



• Cheese Plate for 2 [eat in/take away] \$30
 A selection of cheeses, woodfired sourdough bread
 & seasonal accompaniment
 extras: olives or prosciutto or spiced cherries
 or smoked salmon \$3 each

• Cheesemakers choice [eat in] \$19.50
 cheese of the day
 & accompaniment, woodfired toast or sourdough bread
 your choice of wine or sparkling cider/flower

• Baked OTTO \$24
 serve w/ sourdough bread
 & pear relish

• Woodfired Sourdough PIZZA \$18
 w/ Tom & (2) cheese, tomato sauce
 extra: olives or prosciutto or smoked salmon or
 hand-dipped pesto

• Sourdough Toastie \$10 ea
 w/ local wild ham, Kawmilk C cheese,
 & good mustard

• Serve of woodfired rustic & grains \$6.50

Coffee & Tea \$4
 Chai Tea \$5
 Hot chocolate \$4
 Milkshake \$4.50
 choice of honey or coffee

Bruny Is. wine \$9.95/6.50
 1.0 liter
 3rd in wood fired & earth
 crust oven & bay
 w/ choice of sausage \$7.50

prosciutto + vinefruit toast w/ butter! 7.4.50



1" eyelets

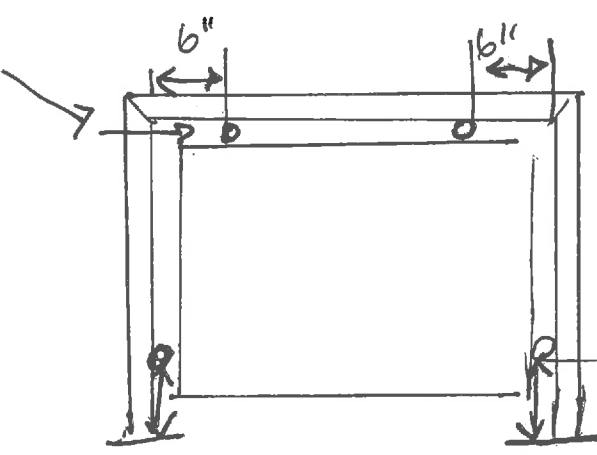

overall sign bracket
 43" x 56" exterior dimensions
 2 1/2 square tubing

16" sidewalk

PLEASE REVIEW CAREFULLY

This proof represents the size, color, and look of your sign. Once the proof is approved it proceeds into production as it appears here. If you have any changes, additions, or questions please let us know and we will revise the proof as requested. We provide unlimited revisions and will not produce your sign until we have an approval from you. Austin Sign Co is not responsible for reprints if the sign produced matches the proof that was approved.

47"

26.5"



Qty: 1, Double Sided Contour Cut MDO

Customer: Stella's

Date: 08-20-15

Qty: 1

Estimated Completion Date:

Size: 26.5" x 47"

Color Specs (if specified): Full Color

Material: Double Sided MDO, Contour Cut

Material Thickness: 1/2"

PLEASE REVIEW ALL ASPECTS OF YOUR PROOF.
You are responsible for color, misspellings, and punctuation.

Please contact us with any questions.